

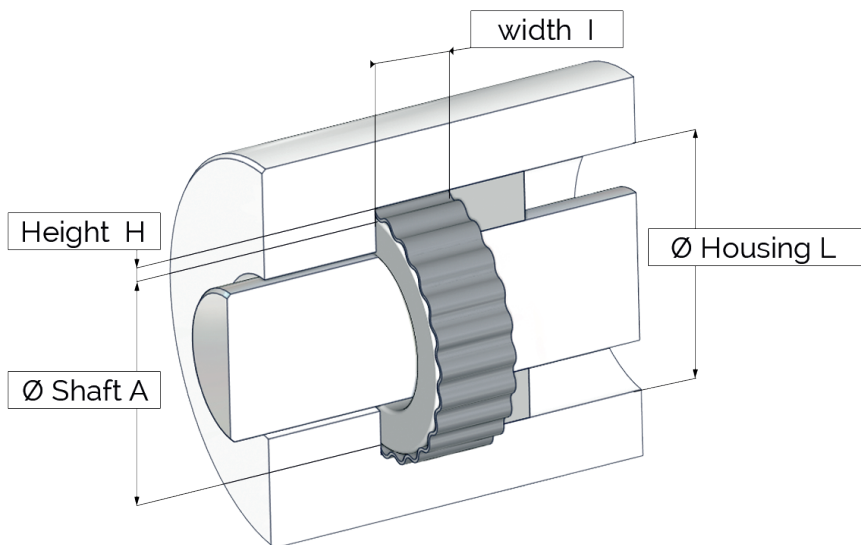

SPACE REQUIRED



Housing diameter L* :mm
 Shaft diameter A* :mm
 Working height H min :mm
 Working height H max :mm
 Working width l :mm

Centering mode

- Housing L
- Shaft A



Free height H₀

H₀ min :mm
 H₀ max :mm

SPRING RATE

k min : N/mm
 k max : N/mm

ENVIRONMENT

Operating temperature :

Mini* :°C Maxi* :°C

- Spring ring operates in oil
- Spring ring must be stainless
- Spring ring should not be magnetic
- Spring ring must be conductive

Surrounding chemical substances :

Required raw material :

FATIGUE

- Static application
- Dynamic application
 - Operating frequency : Hz
 - Number of cycles :

QUANTITIES

Prototypes :
 Pre serie :
 Serie* :
 Annual :

APPLICATION DESCRIPTION

.....

IDENTIFICATION

Last Name* : First Name* :
 Company* : Function :
 Full adress :
 Email* : Phone :

*Required field